

TB014

FULLY HYDRAULIC COMPACT EXCAVATOR



TAKEUCHI

TAKEUCHI

THE HIGHLY TB014 MINI

One of Takeuchi's biggest selling mini-excavators, its operating weight of 1525Kg. (Cab) makes it ideal for the operator requiring performance and transportability. Just load onto a trailer and away you go. With a dig depth of 2135Kg. it can be quickly fitted with buckets, breakers, augers or other attachments and its operator comfort is second to none. Canopy model available at 1410Kg. Legendary Japanese build quality means reliability second to none.



EASY ACCESS & MAINTENANCE



VERSATILE EXCAVATOR

**SUPERB
OPERATOR
COMFORT**



**FULL CAB
VERSION
AVAILABLE**

STANDARD FEATURES

- Long reach, heavy duty dozer blade
- Cast iron wrap around protective counterweight
- Steel engine cover
- Automatic fuel bleed system
- Variable displacement piston pumps
- Safety lockout lever for travel and operating controls
- Remote slew lubrication system
- Two way auxiliary hydraulics plumbed to dipper arm
- Two speed travel
- Double flanged track rollers
- Spring applied, hydraulically released disc type parking brake
- Precise response, proportional main control valves
- Simultaneous operation of cab swing and two digging functions with no reduction in working speed
- Cushioned main boom and swing cylinders
- Hydraulic oil cooler
- Protective routing of bucket, arm and auxiliary hydraulic hoses
- Adjustable pilot operated joystick controls with arm rest
- Main boom cylinder guard
- Hydraulic and fuel sight gauges
- Low noise level and EPA exhaust emission compliant engine
- Engine oil 'Safedrain' system
- T0PS/F0PS cab or canopy
- Fully adjustable suspension seat
- Uncluttered operators platform with hand and foot operated travel controls
- Vandalism protected lockable fuel tank and engine compartment
- Lockable operator's manual and tool storage compartments
- Boom mounted work lights
- Entry from both sides on canopy models
- Short pitch rubber tracks

OPTIONS

- 3 Year Warranty
- TKB71 Hydraulic Breaker
- Auger
- QuickHitch

TB014

OPERATING RANGE

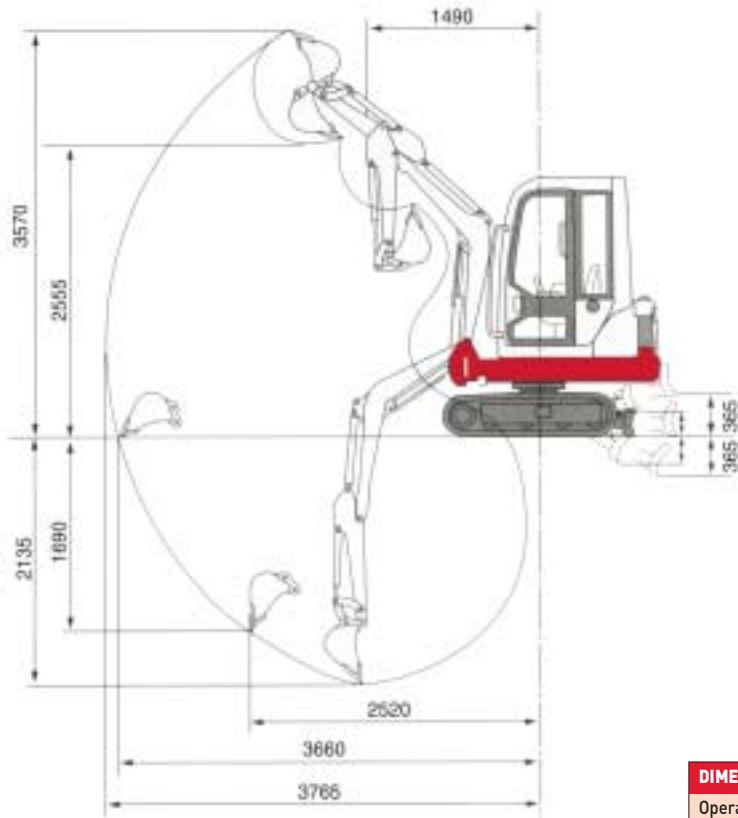

In accordance with our established policy of constant improvement, we reserve the right to amend these specifications at any time without notice. Photographs shown may feature non-standard equipment.

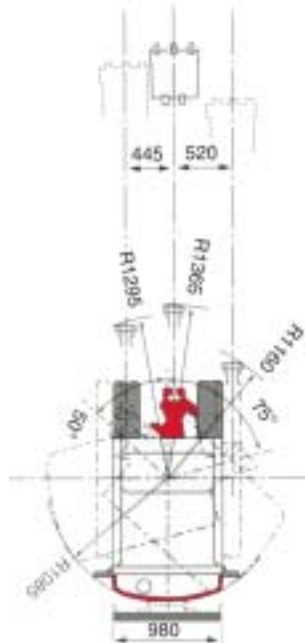
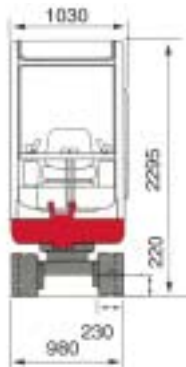

DIMENSIONS & WEIGHT		OPERATING INFORMATION	
Operating Weight (kg)		Max. Dig Depth	2135
Cab/Canopy	1525/1410	Max. Dump Height	2555
Length (transport)	3700	Max. reach at ground level	3660
Width	980	Max. Vertical Dig Depth	1690
Height (Cab/Canopy)	2295/2280	Max. Bucket Dig Force (Kn)	12.1
Ground Clearance	220	Max. Arm Dig Force (Kn)	8.5
Min front swing radius (Cab/Canopy)	1200/1050	UNDERCARRIAGE	
Tail swing radius	1085	Traction Motor	Axial Piston
Dozer Blade (wxh)	980x300	Traction Drive	Planetary
ENGINE		Traction Brake	Disc
Make/Model	Yanmar3TNE68-NTB	Track Width	230
Rated Output/RPM	9kW/2300	Ground Contact Length	1015
Maximum Torque	51Nm	Ground Pressure (kpa)	26.4
Cylinders/Displacement	3/784cc	Travel Speed (K/ph)	2.4/4.6
Electrical System	12volt 40amp	Maximum Gradeability	30°
SWING SYSTEM		HYDRAULIC SYSTEM	
Boom Swing angle (L/R)	75°/50°Cab90°/50°Canopy	Set Pressure (bar)	185
Slew Speed (rpm)	9	Pump Type	Variable(P1+P2)+Gear(P3)
Slew Motor	Orbital Piston	Hydraulic Flow (l/min)	16.4x2+10.1
		Auxiliary Flow (l/min)	33
		CAPACITIES (l)	
		Hydraulic system	33
		Fuel tank	21
		Engine Lubrication	2.8
		Cooling System	2.9

TAKEUCHI

Takeuchi Mfg (UK) Ltd, Lynroyle Way, Rochdale, Lancs OL11 3EX Tel: 01706 657722 Fax: 01706 657744
e-mail: sales@takeuchi-mfg.co.uk www.takeuchi-mfg.co.uk

Southern Office at Thatcham, Newbury Tel: 01635 877 196 Fax: 01635 877 195